

**Vibra
Vibra-K Consultants Ltd.**

**Vibra
Vibra-K Consultants Ltd.**

Methodical Phase Analysis

by

François (Frank) Gagnon

© 2007 by Frank Gagnon

**Vibra
Vibra-K Consultants Ltd.**

April 2007 / Frank Gagnon

Breaking Down PHASE ANALYSIS into EASY STEPS

© 1999, 2007 by François Gagnon
Vibra-K Consultants Ltd.

fgagnon@vibra-k.com

The machine illustration is © 1997 Technical Associates of Charlotte and is used under “Fair Use” as a teaching adjunct to expanded material developed by Frank Gagnon

© 2000

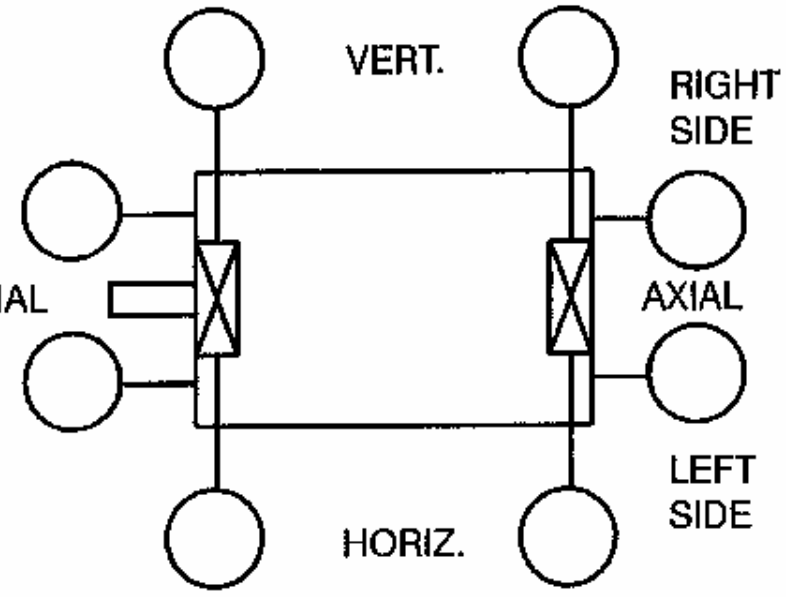
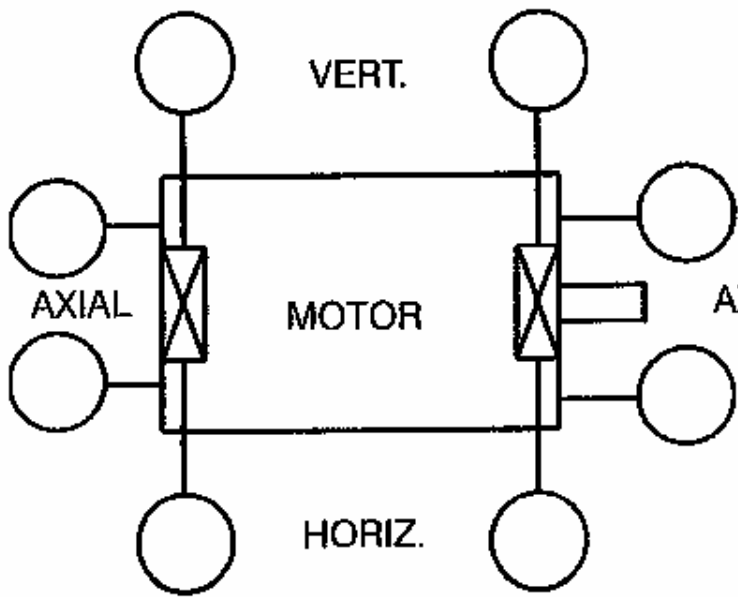
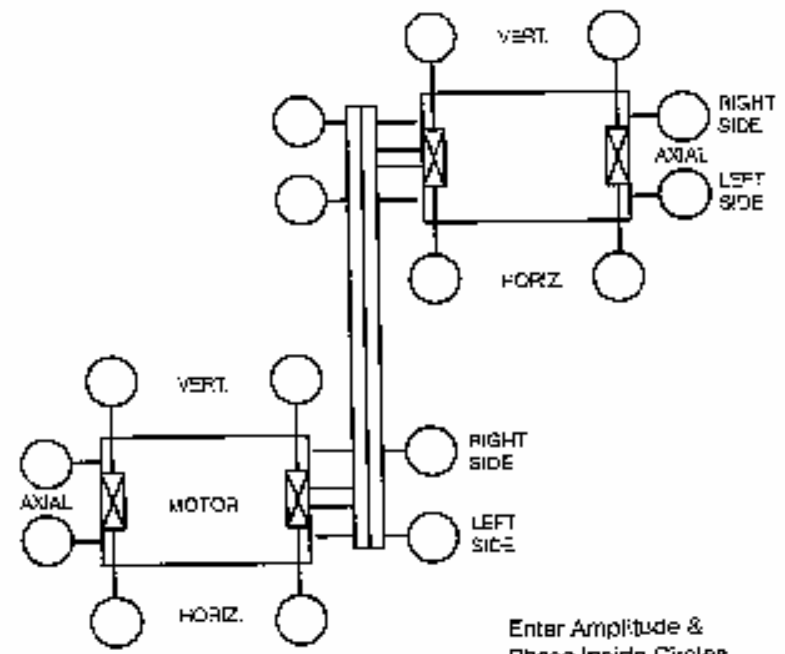
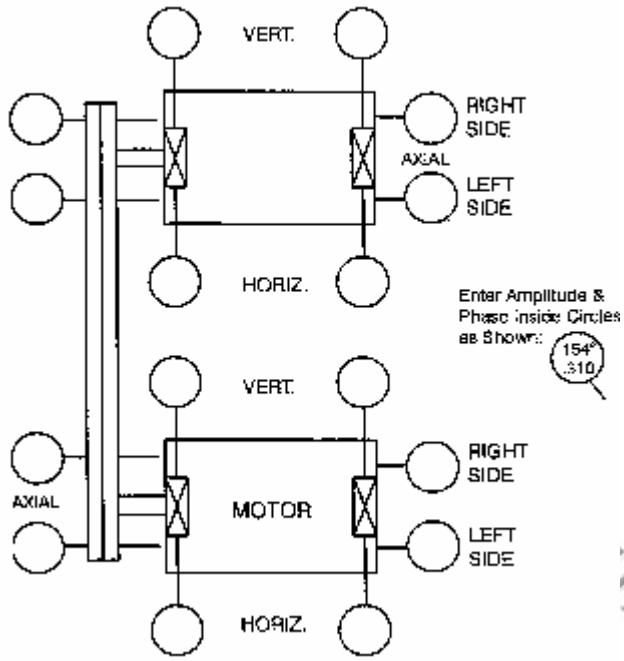

Ultante

Phase & Unbalance

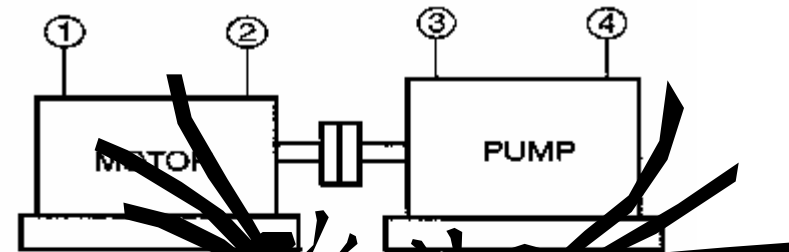

TABLE A.
PHASE AT 1X RPM FOR A MACHINE
WITH DOMINANT COUPLE UNBALANCE

DIR.	1	2	3	4
A	60°	120°	60°	*80°
H	90°	150°	30°	40°
V	120°	110°	120°	135°

* Corrected Phase Values Accounting For 180°
Orientation of Accelerometer.

TABLE B.
PHASE AT 1X RPM FOR A MACHINE
WITH DOMINANT COUPLE UNBALANCE

DIR.	2	3	4
A	*70°	60°	*80°
H	210°	200°	220°
V	120°	295°	280°

* Corrected Phase Values Accounting For 180°
Orientation of Accelerometer.

TABLE C.
PHASE AT 1X RPM FOR A MACHINE
WITH SIGNIFICANT DYNAMIC UNBALANCE

DIR.	1	2	3	4
A	90°	*70°	60°	*80°
H	30°	90°	80°	70°
V	120°	180°	170°	165°

* Corrected Phase Values Accounting For 180°
Orientation of Accelerometer.

Taking the pain
OUT of phase
analysis

© 2007 Vibra-K Consultants

Phase implies a comparison

- Measured Phase in relation to...
- Rotor position (for balancing)
- Another point or location's measured phase
- What it was "before"

Phase Measurement

- Two-channel execution (comparative phase or complex spectra) offer the simplest approach
- No need for a visible reference off the rotor

Phase Analysis "Tolerance"

- The phase difference seen in the last two slides (tables) of this presentation allow for a "variation"
- Typically 30 degrees
- So 60° is equivalent to 90°

Phase Analysis "Tolerance"

- More than one phenomenon may be driving phase!
- Some authors suggest "up to 40° difference" as a tolerance: we find THIRTY is enough
- The caveat about two or more phenomena acting simultaneously does apply (such as, for example, unbalance AND misalignment)

© 2007 by Vibra-K

Complete Machine

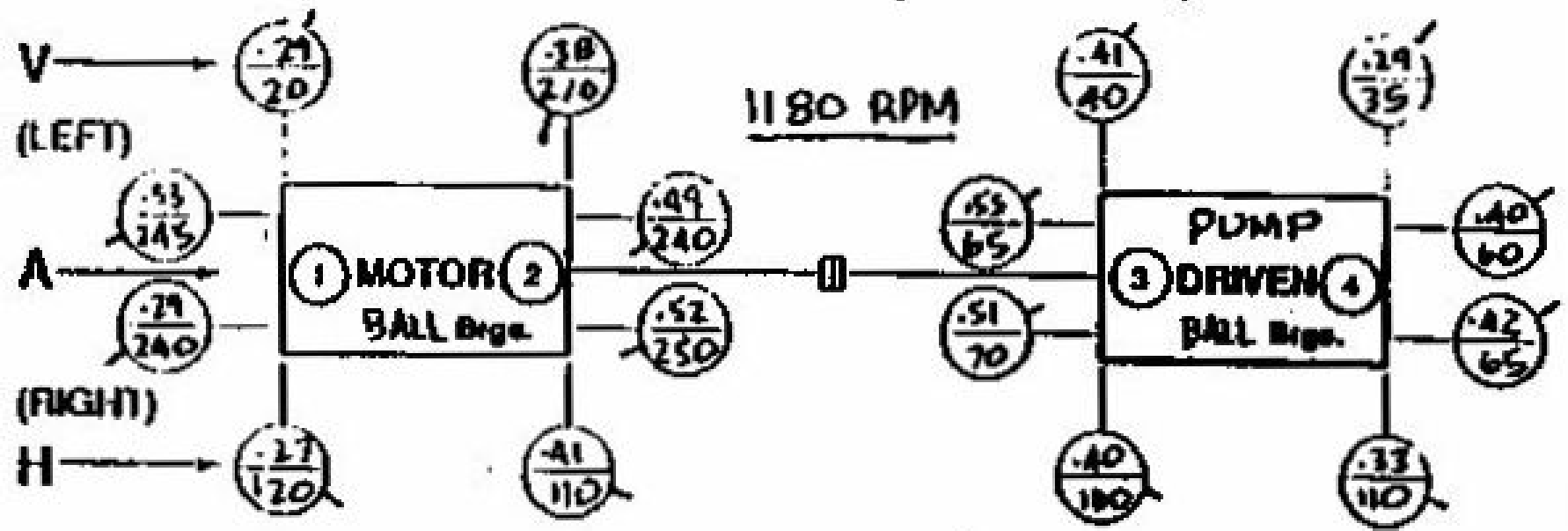

Vibra-K.com

FIRST ROTOR / the motor

One rotor at a time in 6 easy steps

© 2007 by Vibra-K Consultants Ltd - www.vibra-k.com

© 2007 by Vibra-k

First Step / OB Axial

(LEFT)

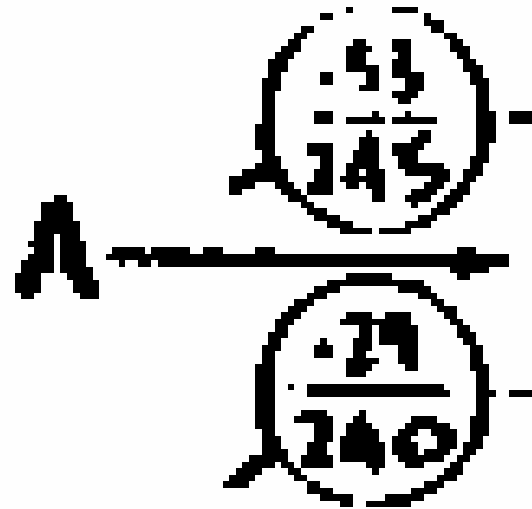

www.vibra-k.com

© 2007 by Vibra-K

2nd Step / IB Axial

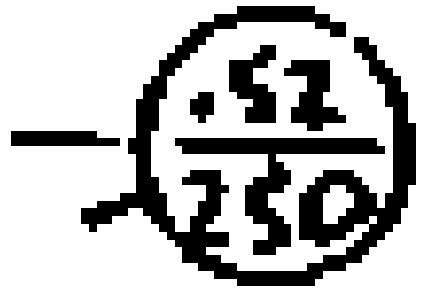

id. - www.vibra-k.com

3rd Step / H Phases together

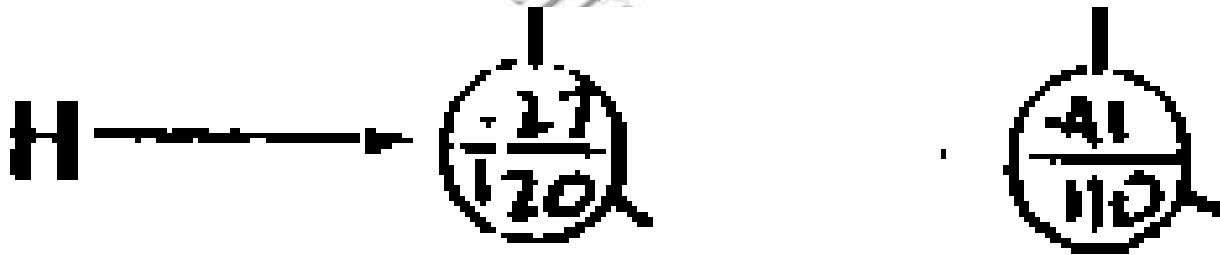

4th Step / Vertical Phases

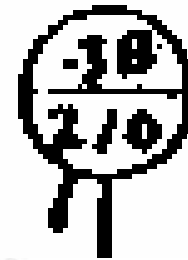
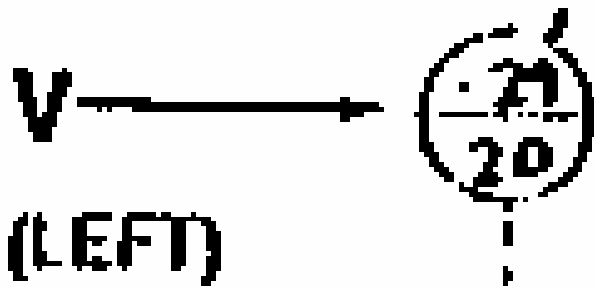

5th Step / Axial Phases Together

(LEFT)



© 2007 by Vibrant

6th Step / H and V

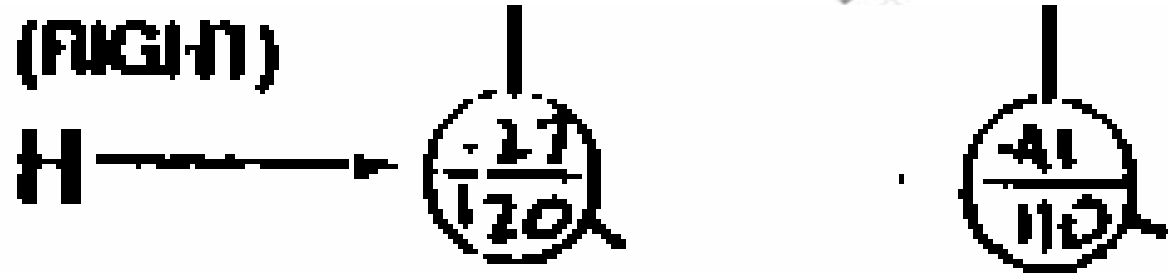

its Ltd.

vbra-k.com

So far, what have we found ?



Second Rotor / the pump

Same six easy steps

1- IB Axial

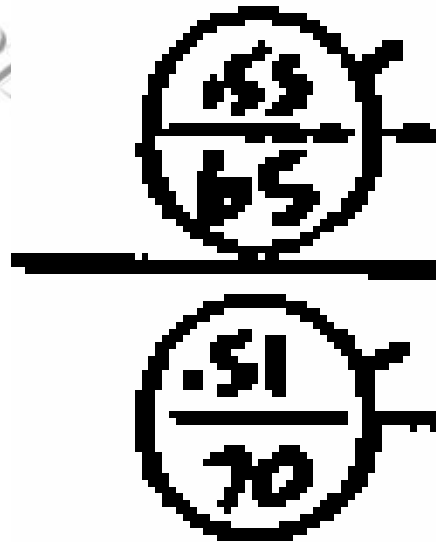

© 2007 by Vibra-K Co.

www.vibra-k.com

2- OB axial

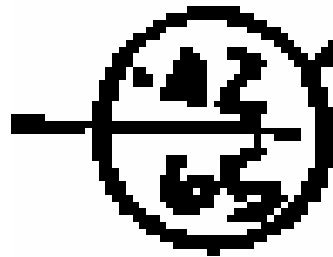
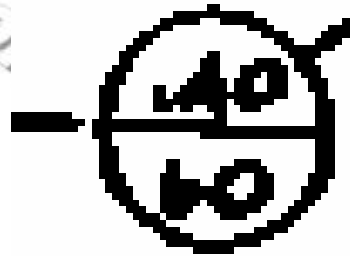

© 2007 by Vibra-K Co.

Ltd. - www.vibra-k.com

© 2007 by Vibra-K Const

3- Horizontal Phases

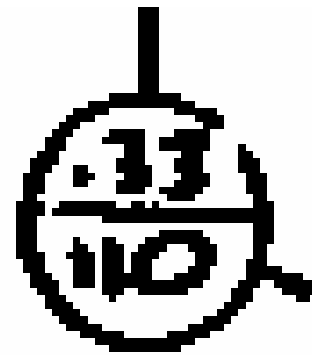
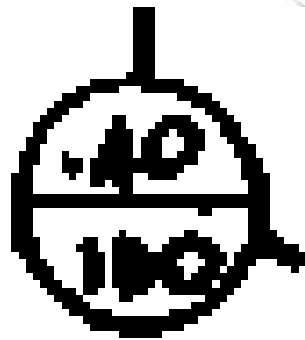

www.vibra-k.com

© 2007 by Vibra-K

4- Vertical Phases

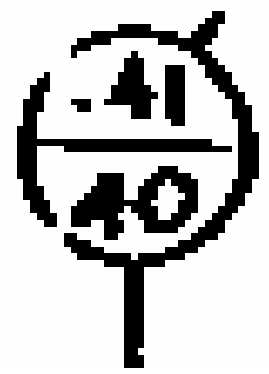

www.vibra-k.com

© 2007 by Vibra-K

5- Axials together

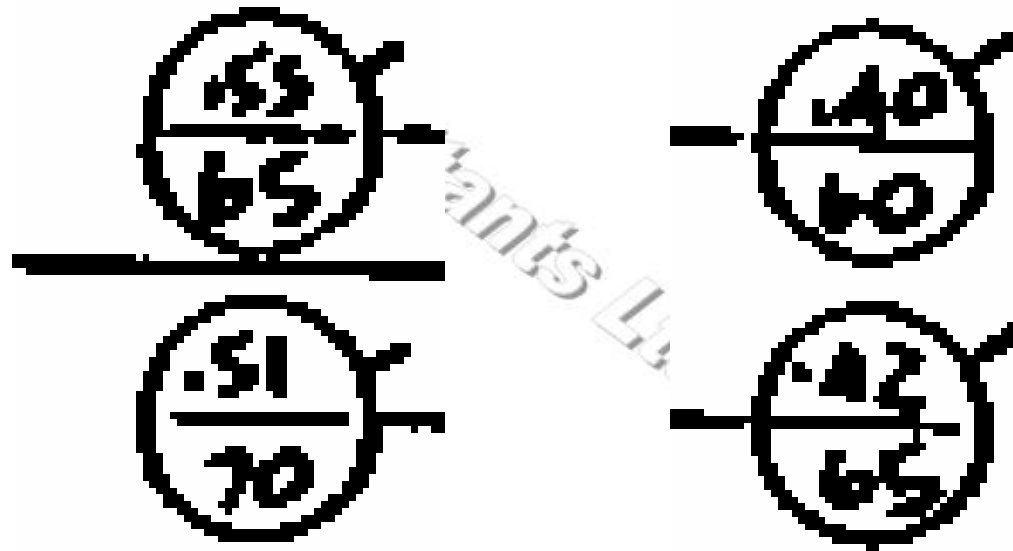

wants L

vibra-k.com

© 2007 by VK

6- H & V Together

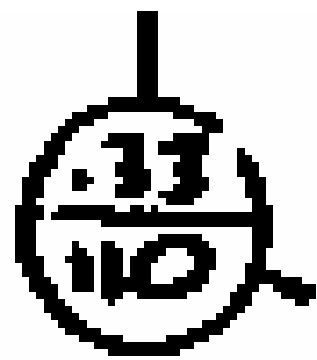
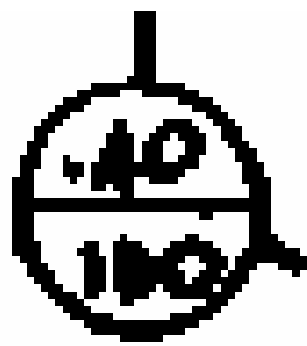
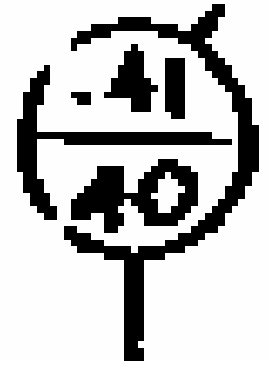

© Ltd

uk.com

© 2007 by Vibra-K Consultants Ltd. - www.vibra-k.com

Both Rotors Together

ACROSS THE COUPLING in
two easy steps

2) Radial Phases across the coupling

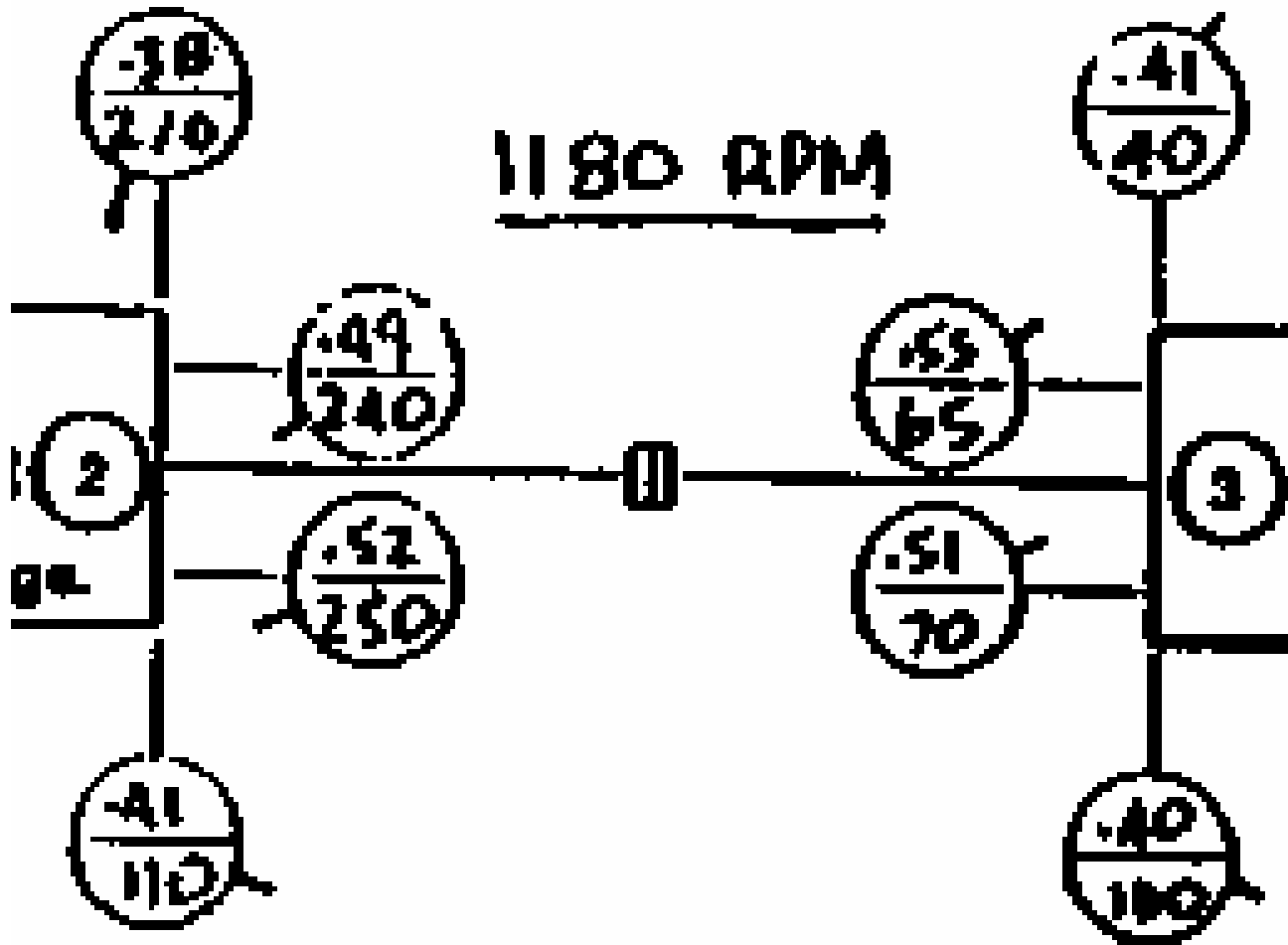

© 2007

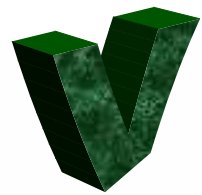

1180 RPM

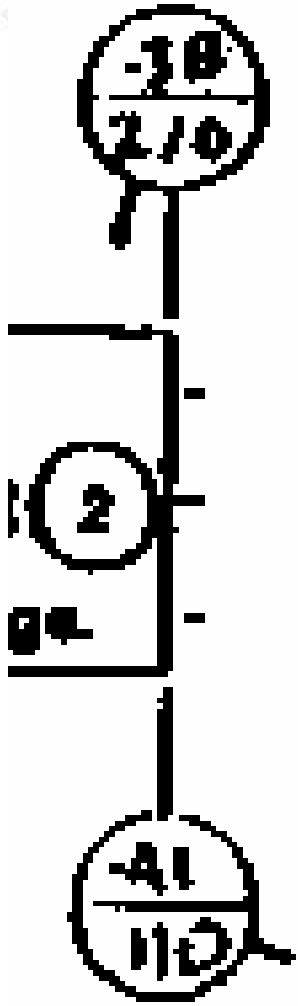

The intervening axial phases have been removed to avoid confusion...

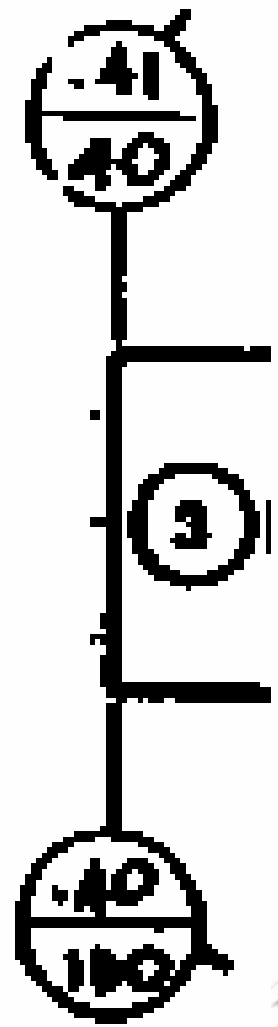
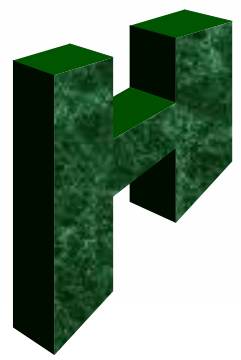

TK.COM

Conclusion ???

- Motor has abnormal vertical phase behavior (180°)
- Axial phases across the coupling are opposed (180°)
- Vertical phase across the coupling are opposed (180°)

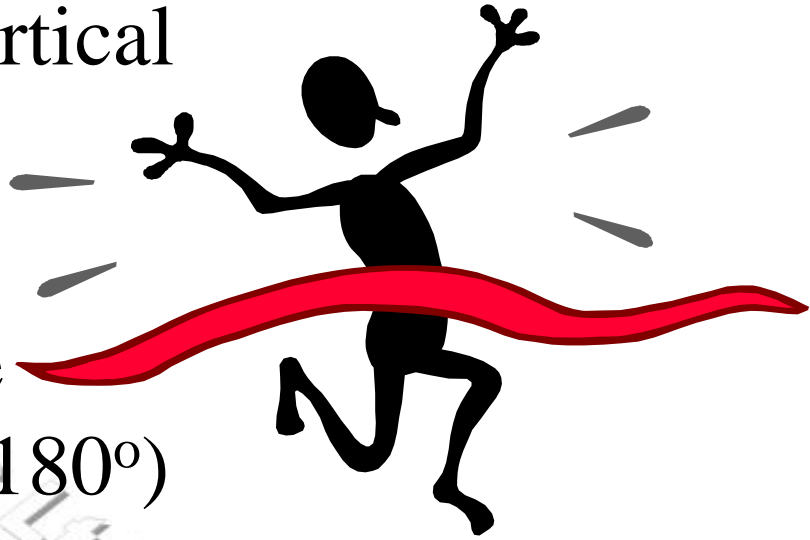

Recap

- Complete phase analysis by seeking abnormalities...
- Review each rotor **ALONE**
 - Single bearing
 - Bearings compared
- Review rotor interface data



© 2007 by Vjorani Consultants Ltd. a-k.com

Radial Phase Analysis

Phase Difference	0°	30 to 60°	90°	120 to 150°	180°
Unbalance (general)			H & V		
Static (force)	H & H V & V		H & V		
Couple			H & V		H & H V & V
Dynamic		H & H V & V	H & V	H & H V & V	
Eccentric	H & V				H & V
Resonance	H & V				H & V
Across coupling	Normal				Misalignment (parallel)

Axial Phase Analysis

Axial Phase	0°	30 to 60°	90°	120-150°	180°
Bearing Face	Normal All points		Abnormal (4 point system)		Abnormal (2 point system)
Across Rotor	Normal				Bent Shaft
Across Coupling	Normal				Angular Misalignment